



Premium Plus Module

290-300W



More Power

Higher conversion efficiency, more power production per unit area



Lower System Cost

Higher conversion efficiency help to save transportation cost, installation cost and BOS cost



Anti-PID



5400Pa

Certified to withstand increased loads of up to 5400pa



1500V - Maximum System Voltage



Fire test resistance



IP68 connectors enhance the reliability of the PV system



10 year product warranty²
25 year performance warranty¹

Note: This datasheet is not legally binding. Phono Solar reserves the right to make specifications changes without notice. Further information can be found on our website: www.phonosolar.com

1. In compliance with our warranty terms and conditions.
2. 12 year product warranty applies when product is registered at phonosolar.com/care

Phono Solar is proudly manufactured in China

PHONO SOLAR AUSTRALIA

Suite 3, 130-134 Pacific Highway, Greenwich NSW 2065

PHONO SALES

184 Bluestone Circuit, Seventeen Mile Rocks QLD 4073

TEL: 07 3160 5259 CONTACT: www.phonosolar.com

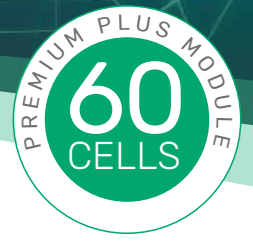

Premium Plus Module

ELECTRICAL TYPICAL VALUES

Model	PS290M-20/U PS290MH-20/U	PS295M-20/U PS295MH-20/U	PS300M-20/U PS300MH-20/U
Type	Monocrystalline 6 inch x 6 inch square, 6 x 10 pieces in series		
Rated Power (Pmpp)	290	295	300
Tolerance	0~+5	0~+5	0~+5
Rated Current (Impp)	9.10	9.20	9.32
Rated Voltage (Vmpp)	31.87	32.07	32.19
Short Circuit Current (Isc)	9.71	9.74	9.82
Open Circuit Voltage (Voc)	39.70	39.80	39.90
Module Efficiency (%)	17.83	18.13	18.44
NOCT (Nominal Operation Cell Temperature)	45°C ± 2°C		
Voltage Temperature Coefficient	-0.288%/°C		
Current Temperature Coefficient	+0.047%/°C		
Power Temperature Coefficient	-0.398%/°C		

MECHANICAL CHARACTERISTICS

Dimension (A x B x C)	Length: 1640mm, Width: 992mm Height: 40mm
Weight	19Kg
Front Glass	3.2mm toughened glass
Frame	Anodized aluminium alloy
Cable	4mm ² (IEC)/12AWG (UL), 900mm
Junction Box	IP 68 rated
Connectors	EVO-2

WEAK LIGHT PERFORMANCE

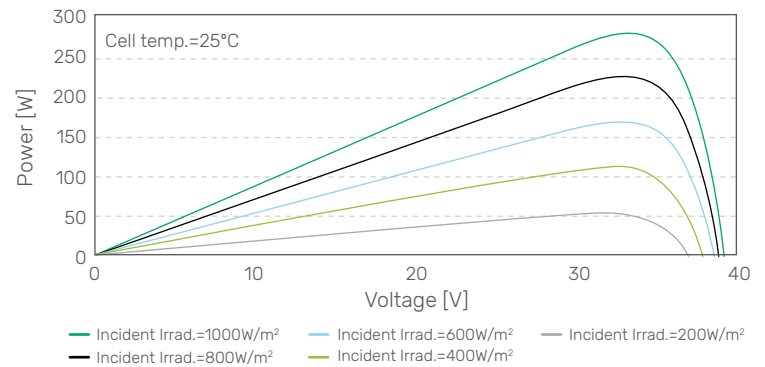

ABSOLUTE MAXIMUM RATING

Parameter	Values
Operating Temperature	From -40 to +85°C
Hail Diameter @ 80km/h	Up to 25mm
Surface Maximum Load Capacity	Up to 5400Pa
Maximum Series Fuse Rating	15A
IEC Application Class (IEC61730)	A
Fire Rating (IEC61730)	C
Module Fire Performance (UL1703)	Type 1
Maximum System Voltage	DC 1000V (IEC) DC 600V (UL)/1000 (ETL) 1500V (ETL)

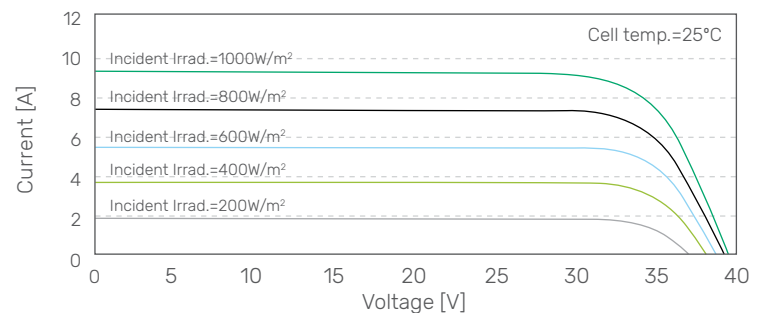

PACKING CONFIGURATION

Container	40' HQ	20'GP
Pieces per container	728	264

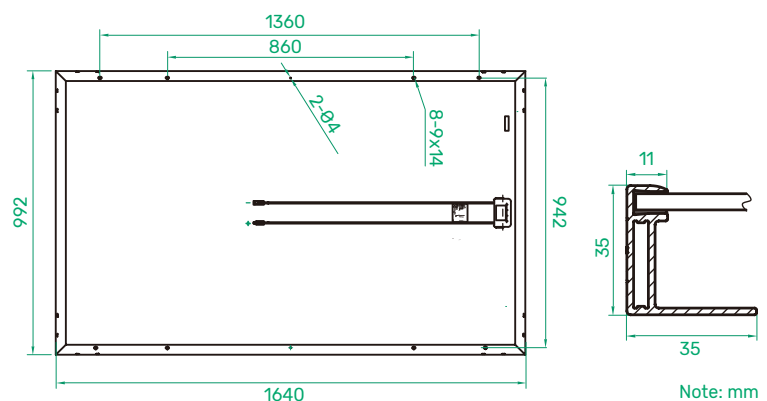

- In compliance with our warranty terms and conditions.
- Measurement conditions under irradiance level of Standard Test Conditions (STC): 1000W/m², Air mass 1.5 Spectrum, cell temperature of 25°C.